

PISOS PLANTA PRIMERA I PLANTA SEGONA

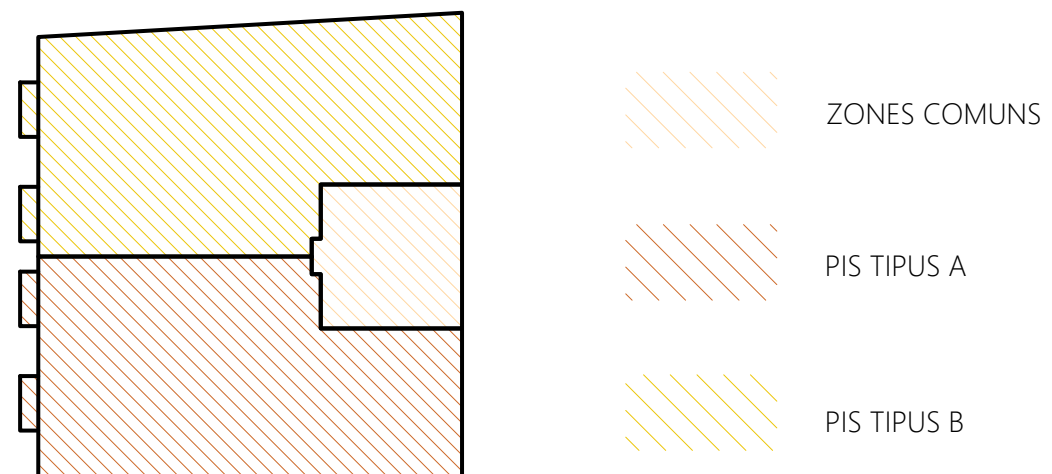

PIS TIPUS A

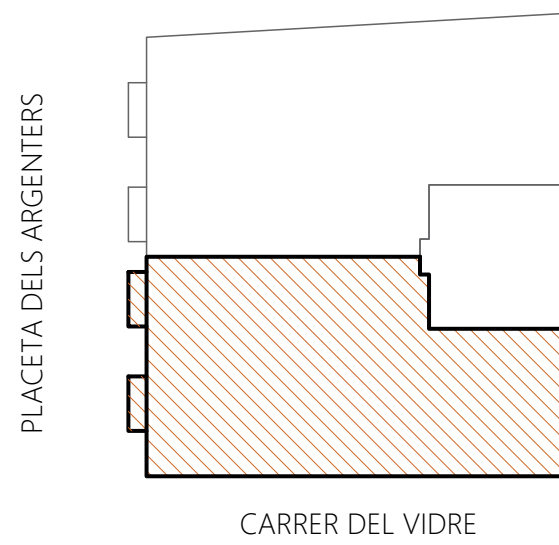

PLACETA DELS ARGENTERS

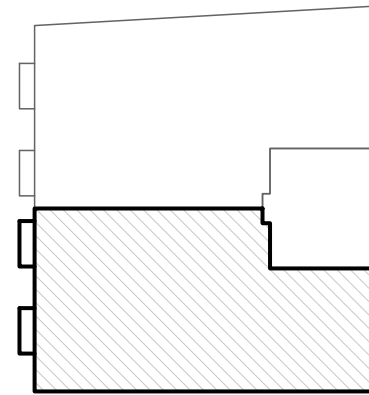

CARRER DEL VIDRE

SUPERFÍCIES ÚTILS

PIS 2-A		m ²
Rebedor		2,70
Passadís		5,55
Bany 1		4,60
Bany 2		2,90
Dormitori 1		15,50
Dormitori 2		10,10
Dormitori 3		9,50
EMC		30,00
Balcons 1 i 2		2,00
TOTAL ÚTIL PIS TIPUS A		82,85

TOTAL ÚTIL HABITABLE PIS TIPUS A	80,85
---	--------------

SUPERFÍCIES CONSTRUÏDES

PIS TIPUS A	90,95 m²
--------------------	----------------------------

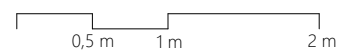
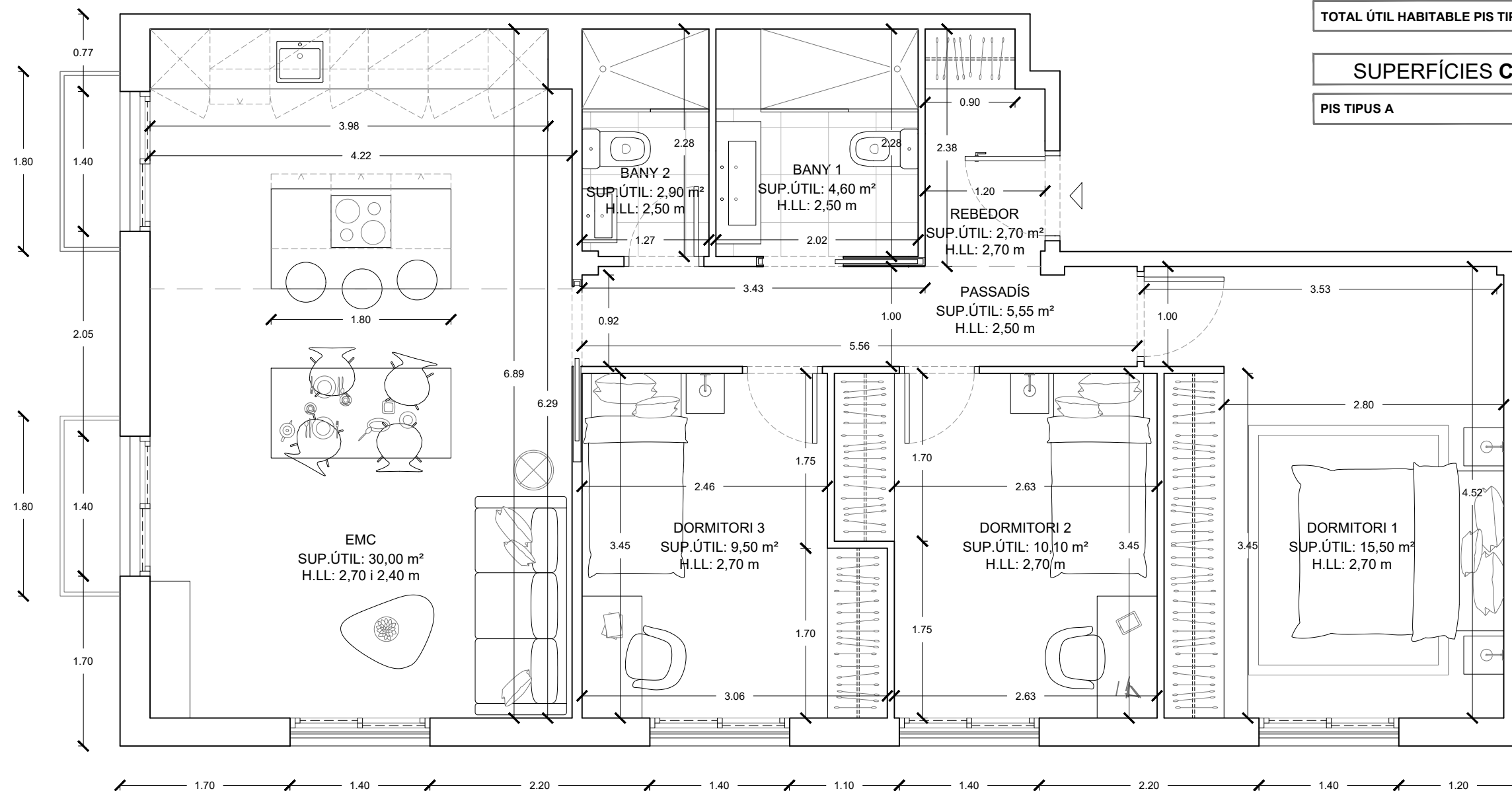

E: 1/50
A3

APCA
taller d'arquitectura
interiorisme i urbanisme

PLÀNOL
Pis tipus A
Cotes i superfícies



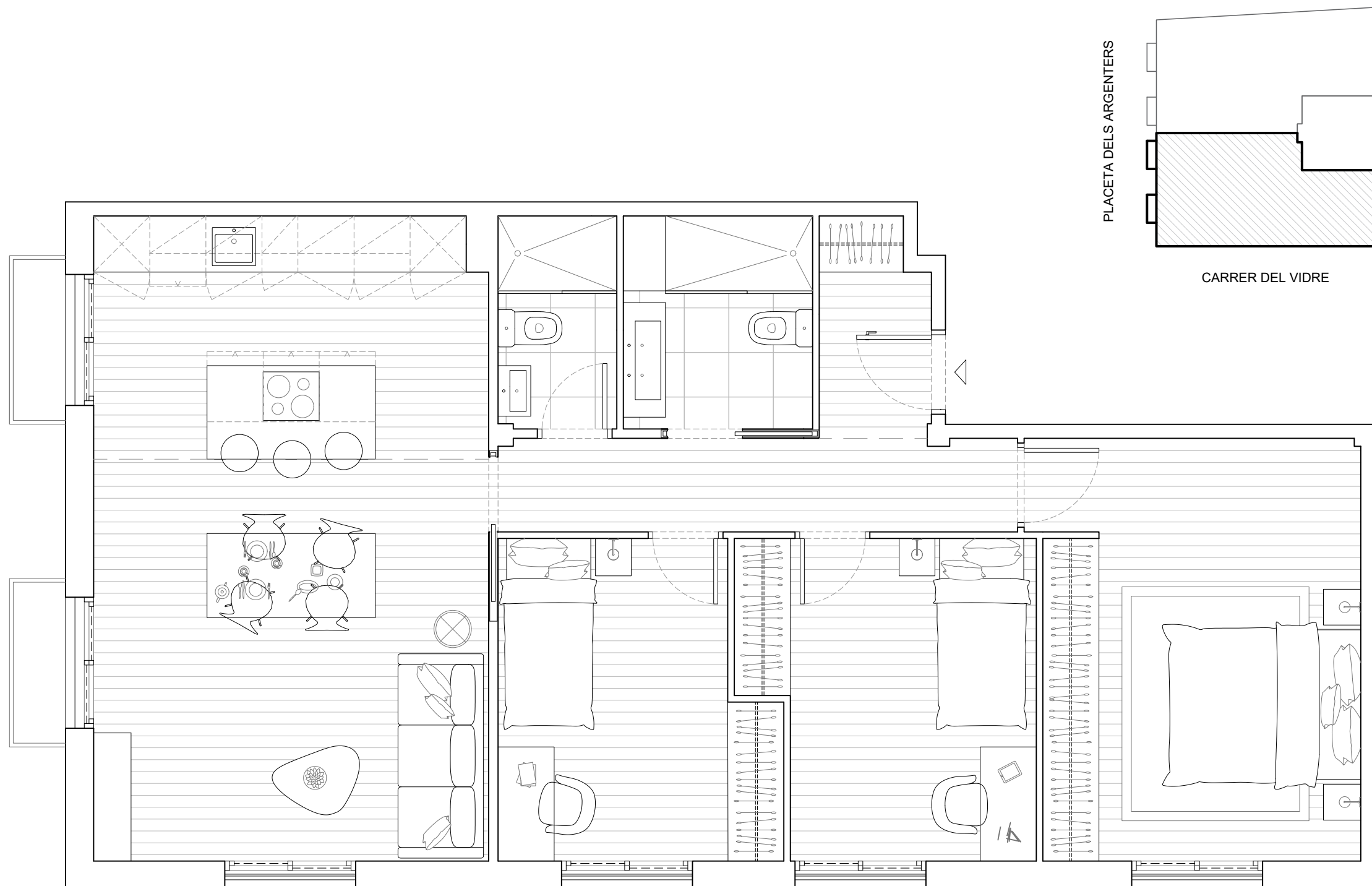

PLACETA DELS ARGENTERS

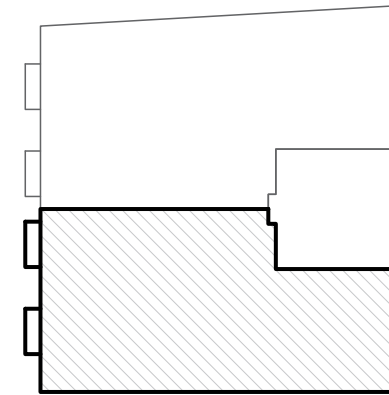

CARRER DEL VIDRE

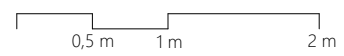

E: 1/50
A3

APCA
taller d'arquitectura
interiorisme i urbanisme

PLÀNOL
Pis tipus A
Distribució



PIS TIPUS B

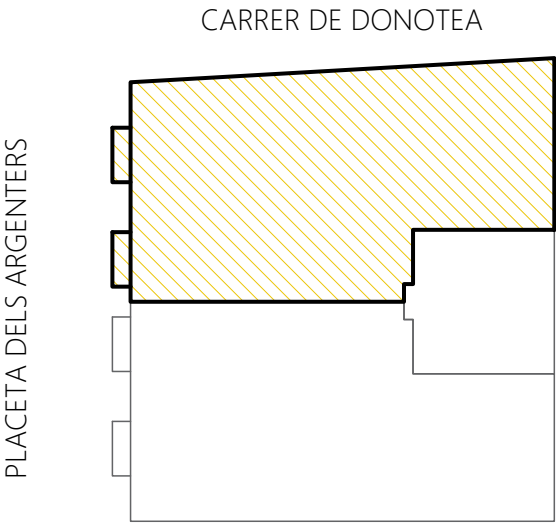

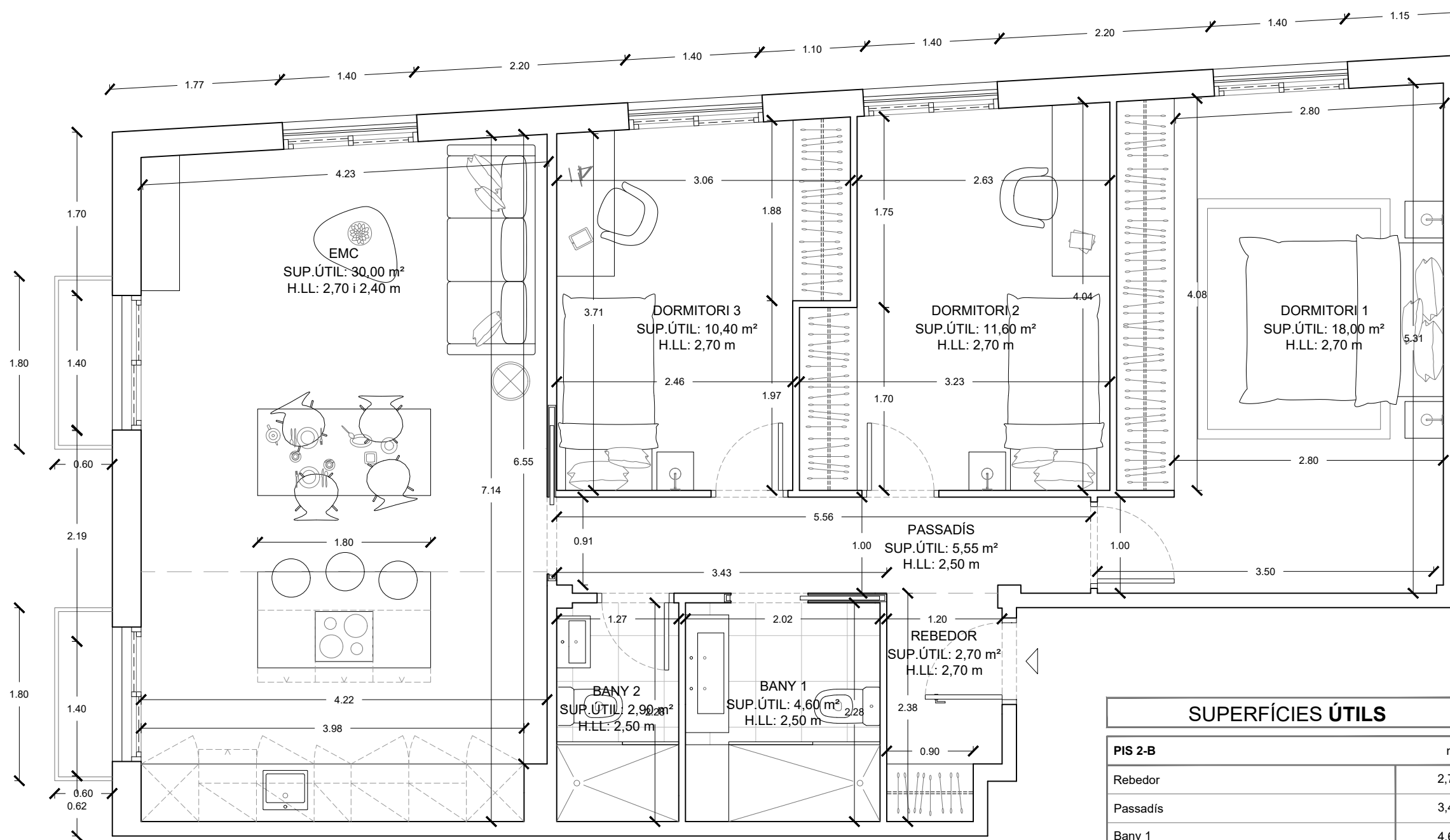

CARRER DE DONOTEA

PLACETA DELS ARGENTERS

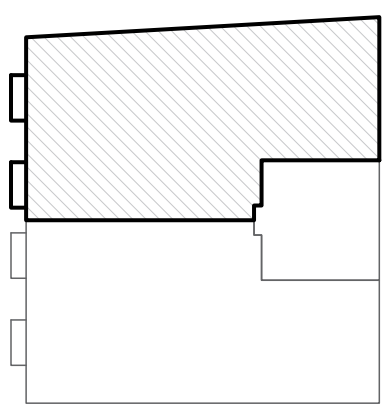

SUPERFÍCIES ÚTILS

PIS 2-B		m²
Rebedor		2,70
Passadís		3,40
Bany 1		4,60
Bany 2		2,70
Dormitori 1		18,00
Dormitori 2		11,60
Dormitori 3		10,40
EMC		30,00
Balcons 1 i 2		2,00
TOTAL ÚTIL PIS TIPUS B		85,40
TOTAL ÚTIL HABITABLE PIS TIPUS B		83,40

SUPERFÍCIES CONSTRUÏDES

PIS TIPUS B	96,55 m²
--------------------	-----------------

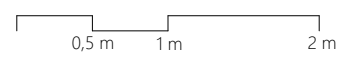

E: 1/50
A3

APCA
taller d'arquitectura
interiorisme i urbanisme

PLÀNOL
Pis tipus B
Cotes i superfícies



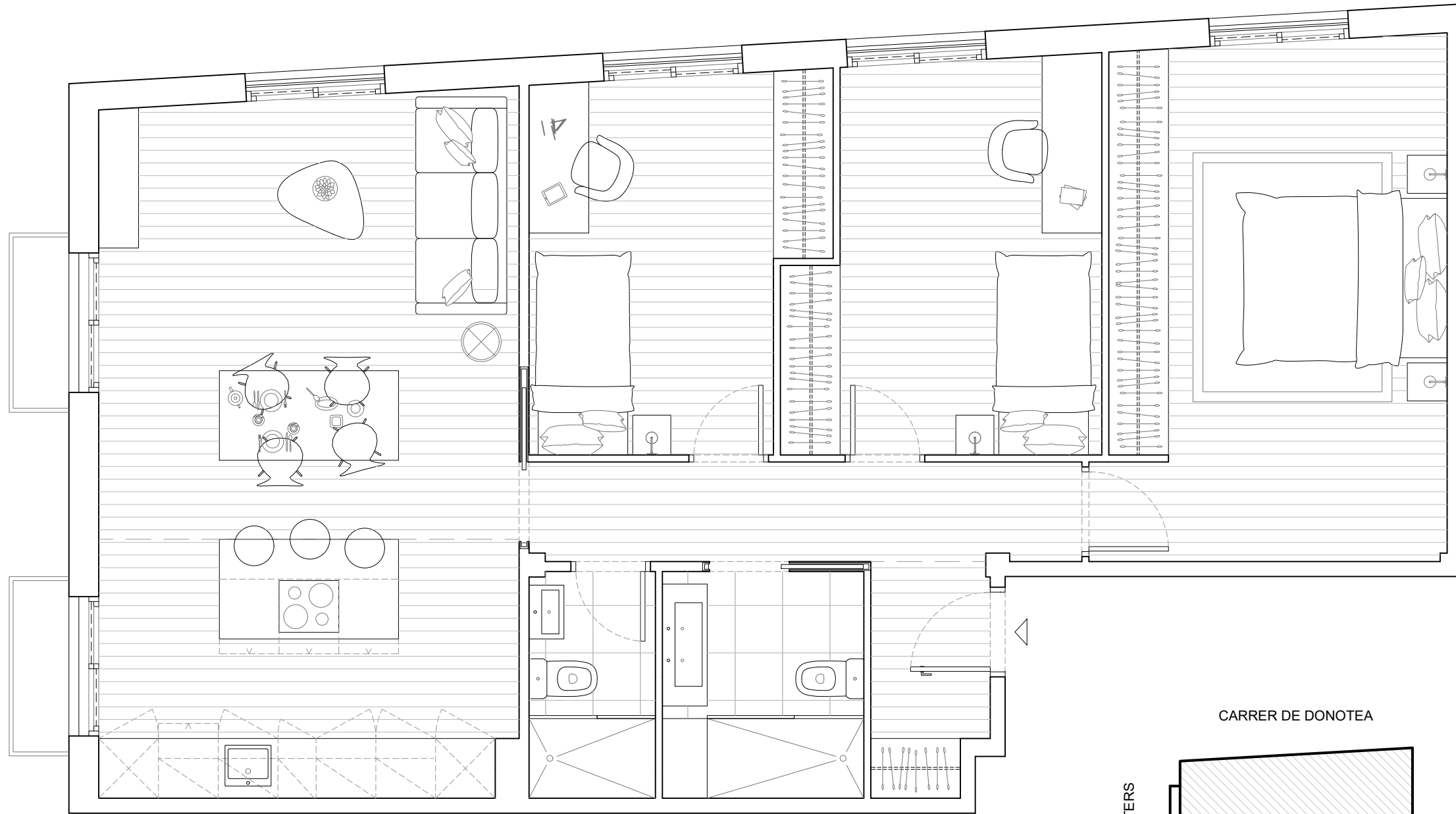

CARRER DE DONOTEA

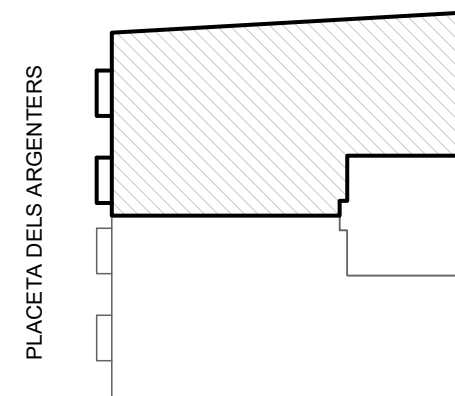

PLACETA DELS ARGENTERS

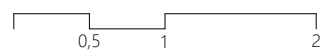

E: 1/50
A3

APCA
taller d'arquitectura
interiorisme i urbanisme

PLÀNOL
Pis tipus B
Distribució



ÀTICS AMB TERRASSA I PISCINA

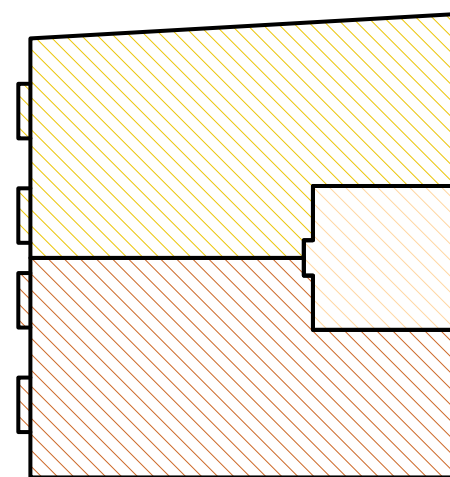

- ZONES COMUNS
- PIS 3-A
- PIS 3-B

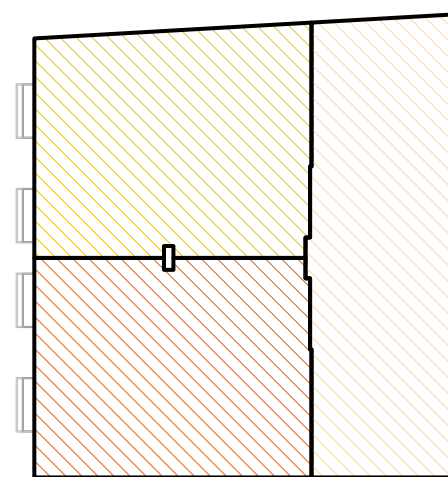

- ZONES COMUNS + ZONA INSTAL·LACIONS
- TERRASSA 3-A
- TERRASSA 3-B

ÀTIC TIPUS A AMB TERRASSA I PISCINA

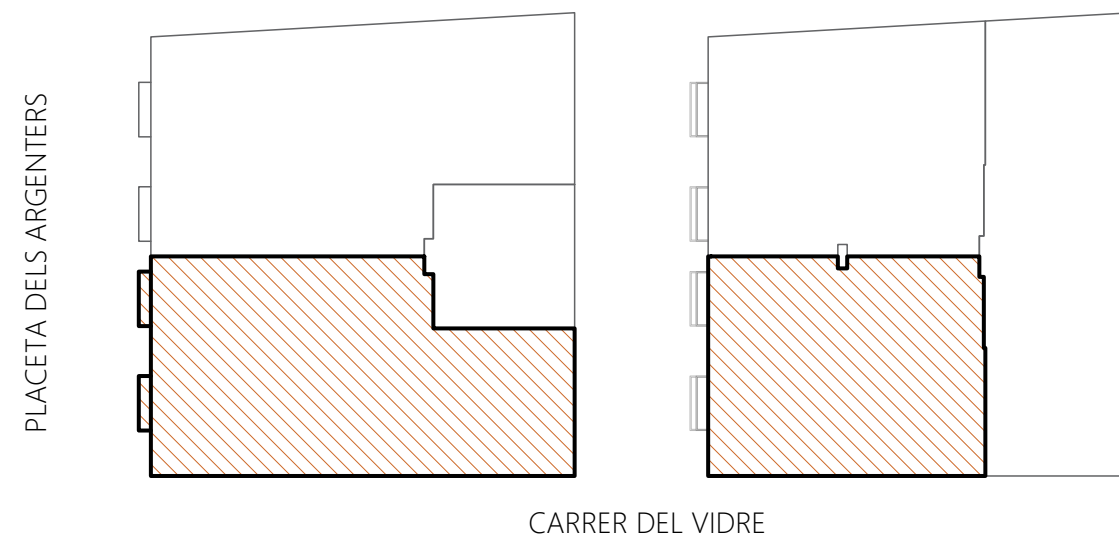

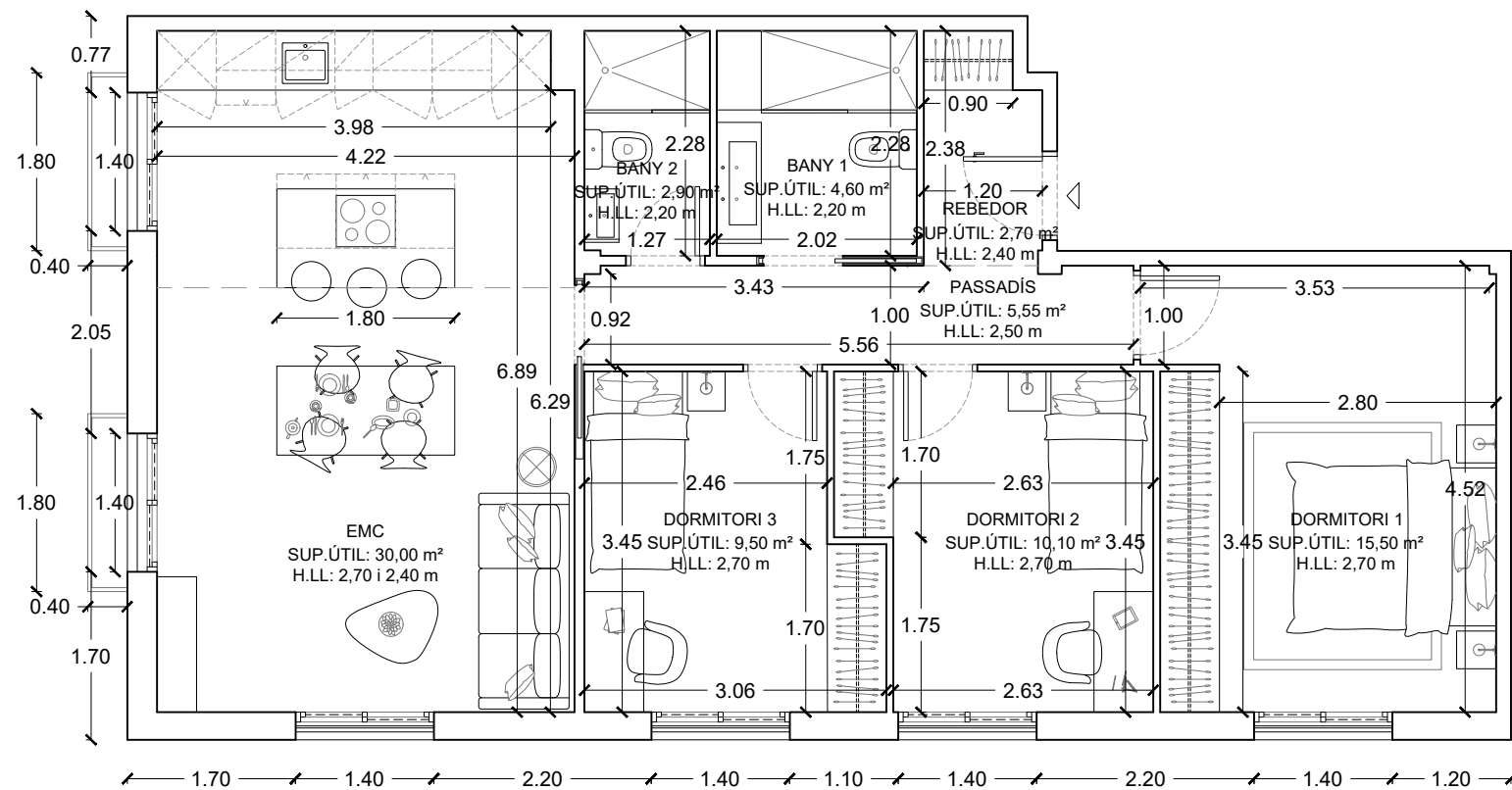
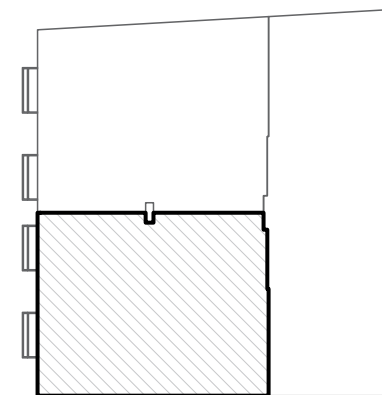
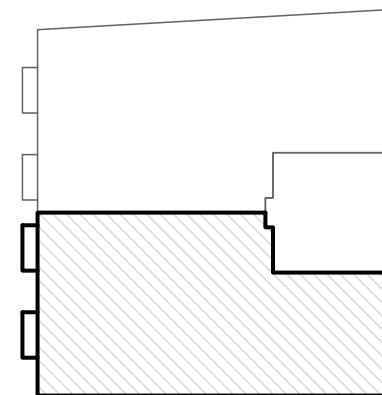
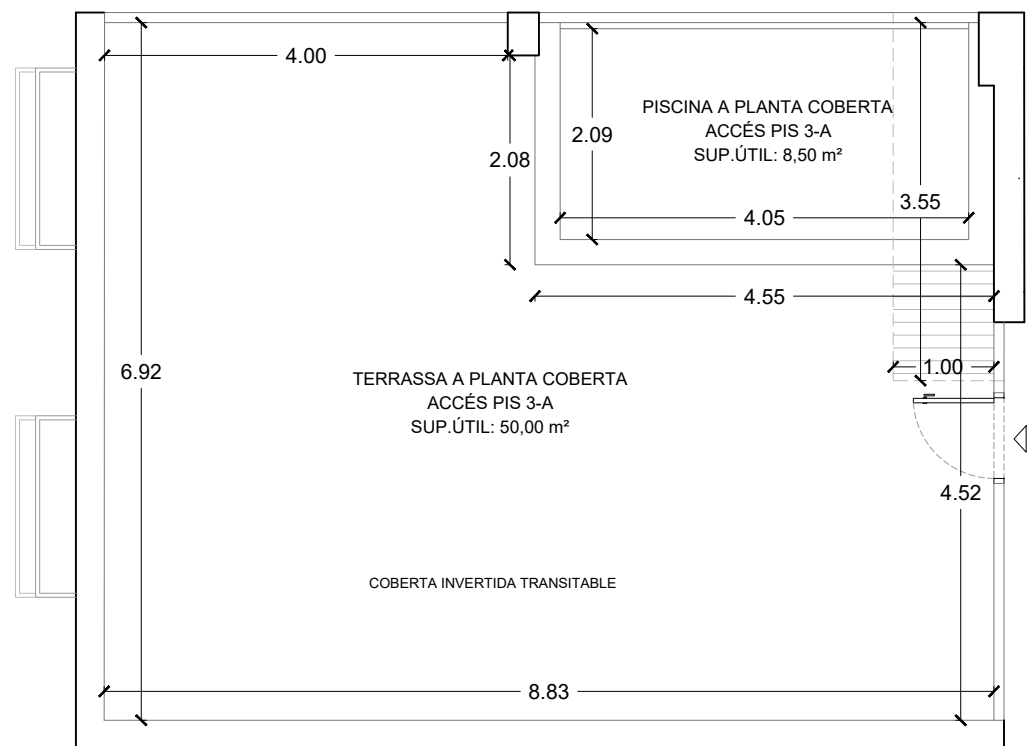

SUPERFÍCIES ÚTILS

PIS 2-A		m ²
Rebedor		2,70
Passadís		5,55
Bany 1		4,60
Bany 2		2,90
Dormitori 1		15,50
Dormitori 2		10,10
Dormitori 3		9,50
EMC		30,00
Balcons 1 i 2		2,00
TOTAL ÚTIL PIS TIPUS A		82,85

TOTAL ÚTIL HABITABLE PIS TIPUS A	80,85
---	--------------

TERRASSA PIS 3-A		m ²
Terrassa		50,00
Piscina		8,50
TOTAL ÚTIL TERRASSA PIS 3-A		58,50

TOTAL ÚTIL PIS TIPUS A AMB TERRASSA I PISCINA	141,35 m²
--	-----------------------------

SUPERFÍCIES CONSTRUÏDES

TOTAL CONSTRUÏDA PIS TIPUS A AMB TERRASSA I PISCINA	156,95 m²
--	-----------------------------

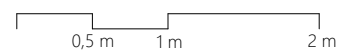

E: 1/75
A3

APCA
taller d'arquitectura
interiorisme i urbanisme

PLÀNOL
Pis tipus A
amb terrassa i piscina
Cotes i superfícies



PLACETA DELS ARGENTERS

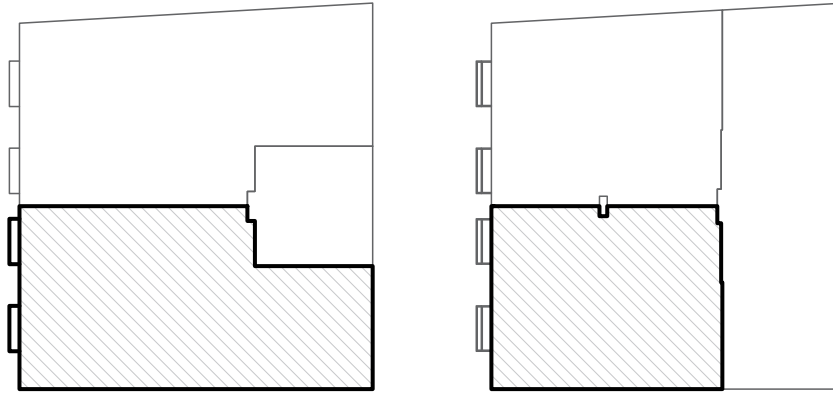

CARRER DEL VIDRE

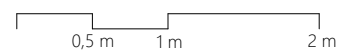

E: 1/50
A3

APCA
taller d'arquitectura
interiorisme i urbanisme

PLÀNOL
Pis tipus A
amb terrassa i piscina
Distribució



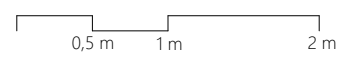
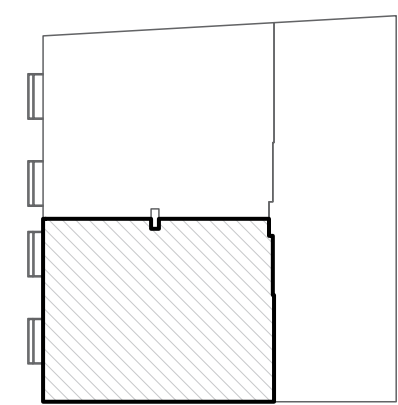
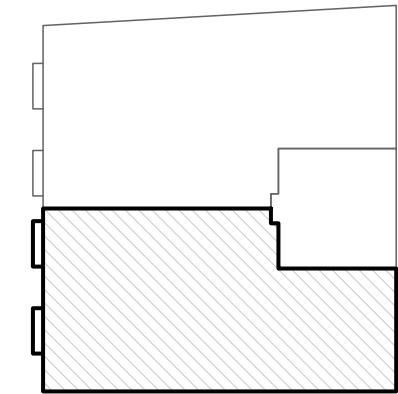
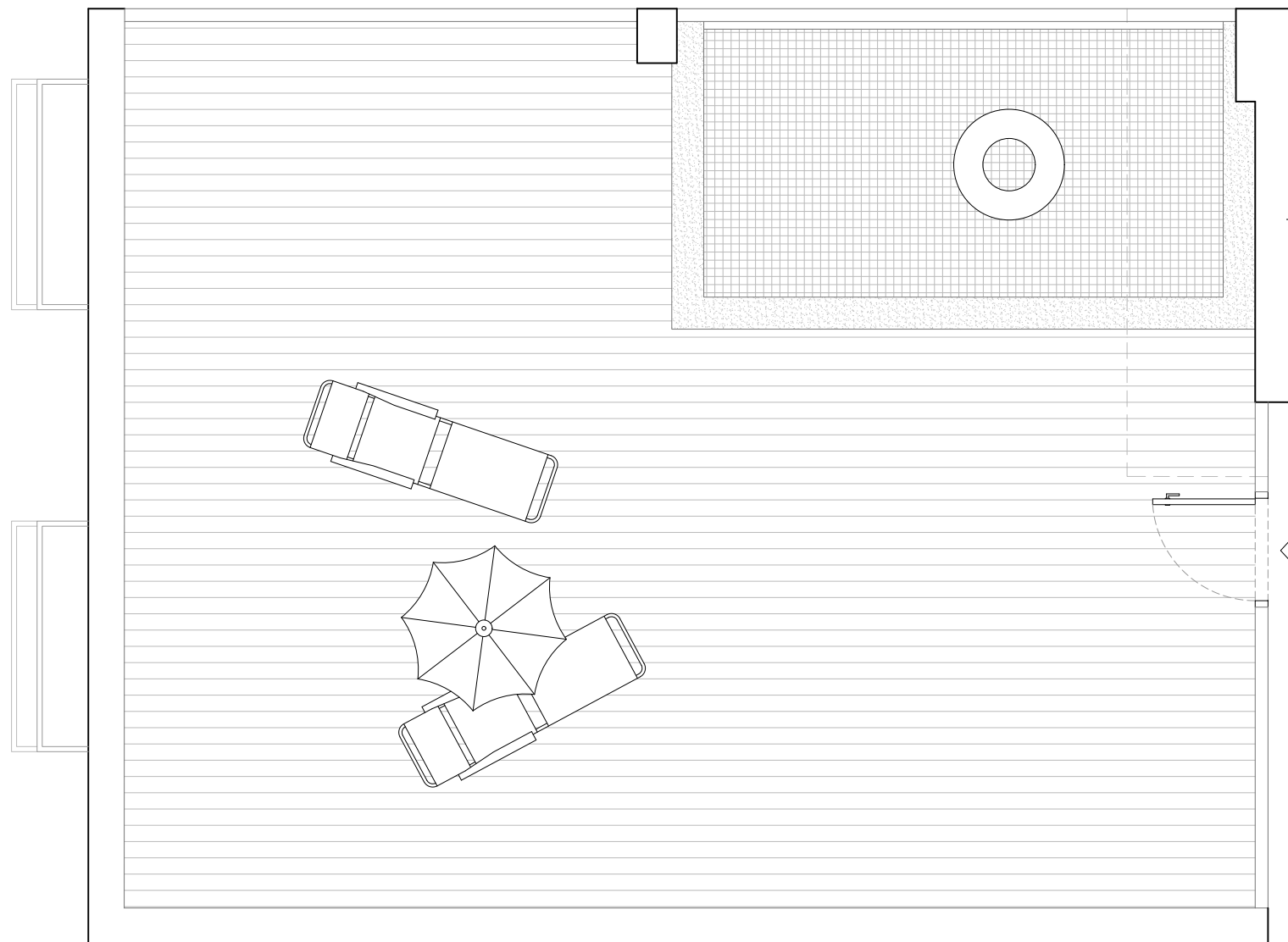

E: 1/50
A3

APCA
taller d'arquitectura
interiorisme i urbanisme

PLÀNOL
Pis tipus A
amb terrassa i piscina
Distribució



ÀTIC TIPUS B AMB TERRASSA I PISCINA

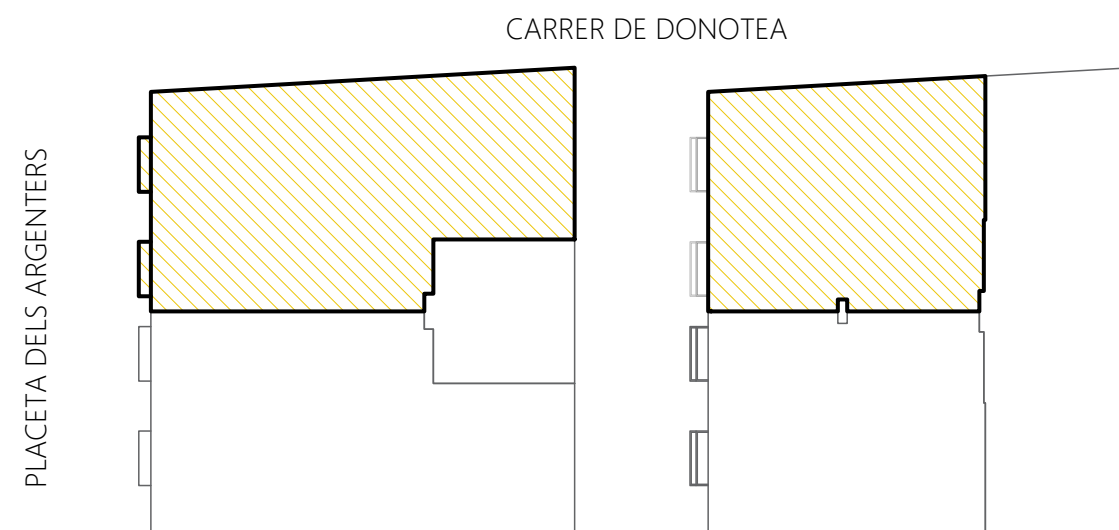

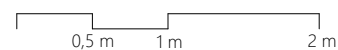
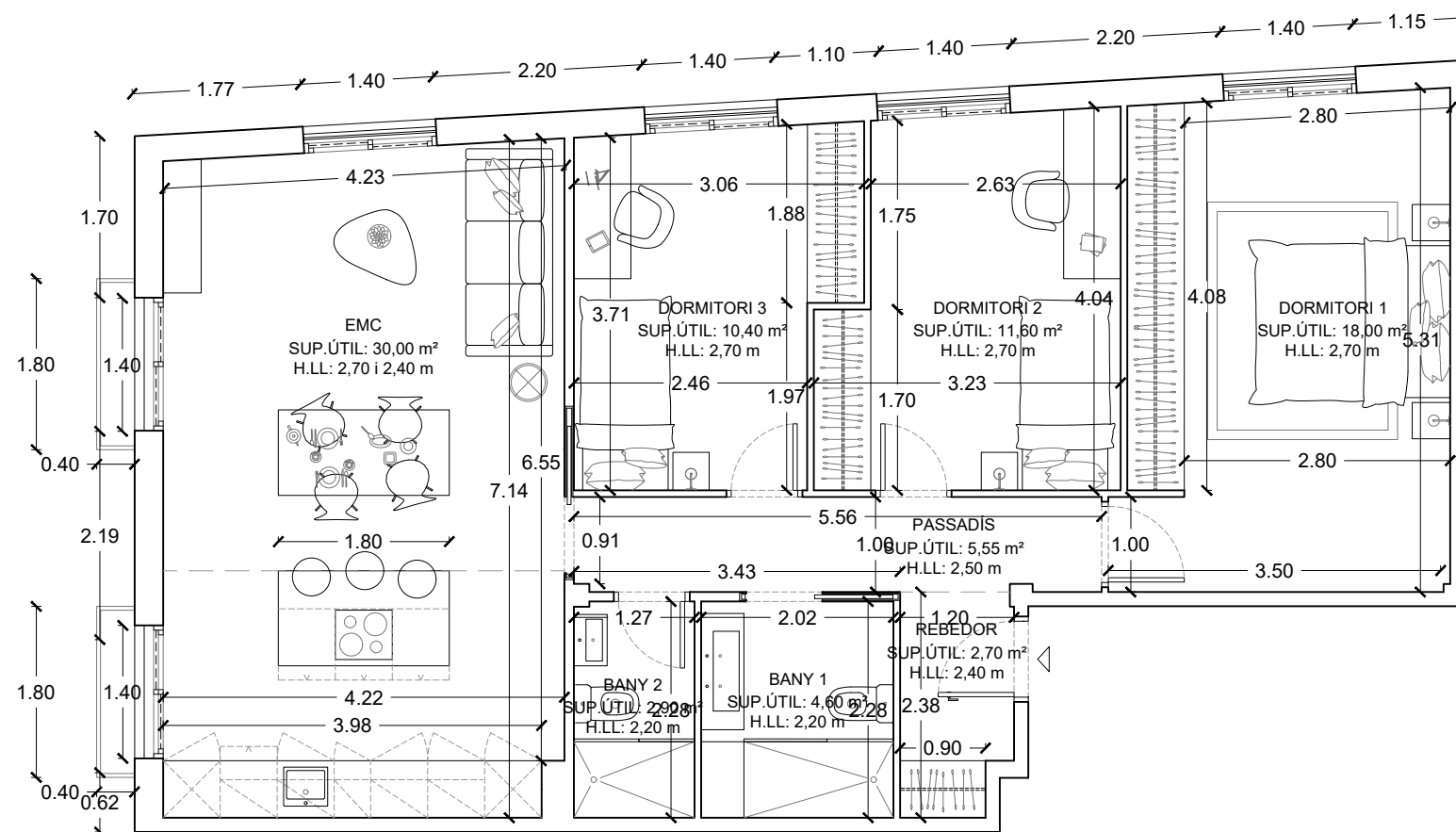
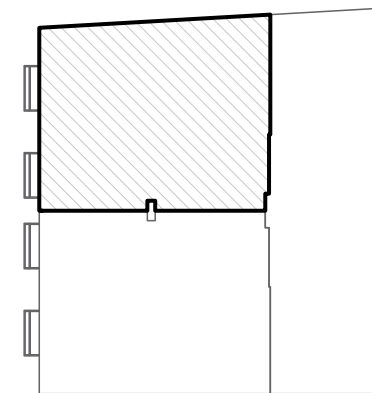
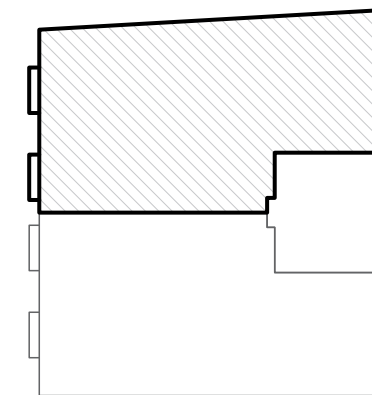
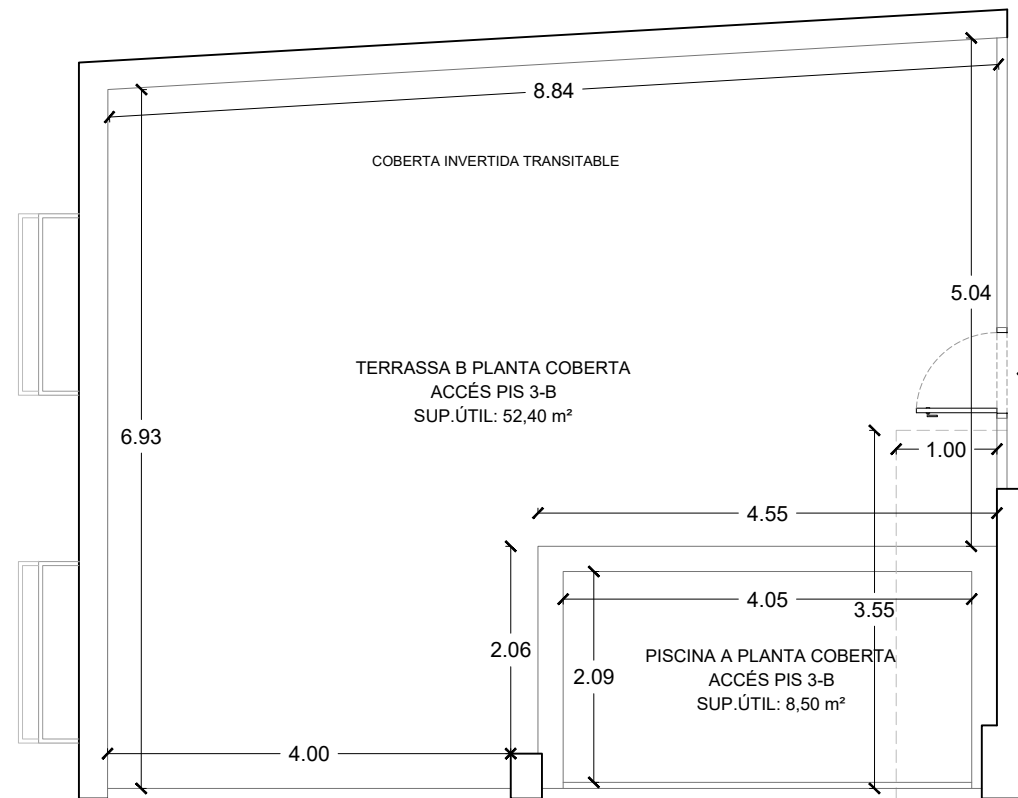

E: 1/75
A3

SUPERFÍCIES ÚTILS

PIS 2-B		m²
Rebedor		2,70
Passadís		3,40
Bany 1		4,60
Bany 2		2,70
Dormitori 1		18,00
Dormitori 2		11,60
Dormitori 3		10,40
EMC		30,00
Balcons 1 i 2		2,00
TOTAL ÚTIL PIS TIPUS B		85,40

TOTAL ÚTIL HABITABLE PIS TIPUS B	83,40
---	--------------

TERRASSA PIS 3-B		m²
Terrassa		52,40
Piscina		8,50
TOTAL ÚTIL TERRASSA PIS 3-B		60,90

TOTAL ÚTIL PIS TIPUS B AMB TERRASSA I PISCINA	146,30 m²
--	------------------

SUPERFÍCIES CONSTRUÏDES

TOTAL CONSTRUÏDA PIS TIPUS B AMB TERRASSA I PISCINA	164,93 m²
--	------------------

APCA
taller d'arquitectura
interiorisme i urbanisme

PLÀNOL
Pis tipus B
amb terrassa i piscina
Cotes i superfícies



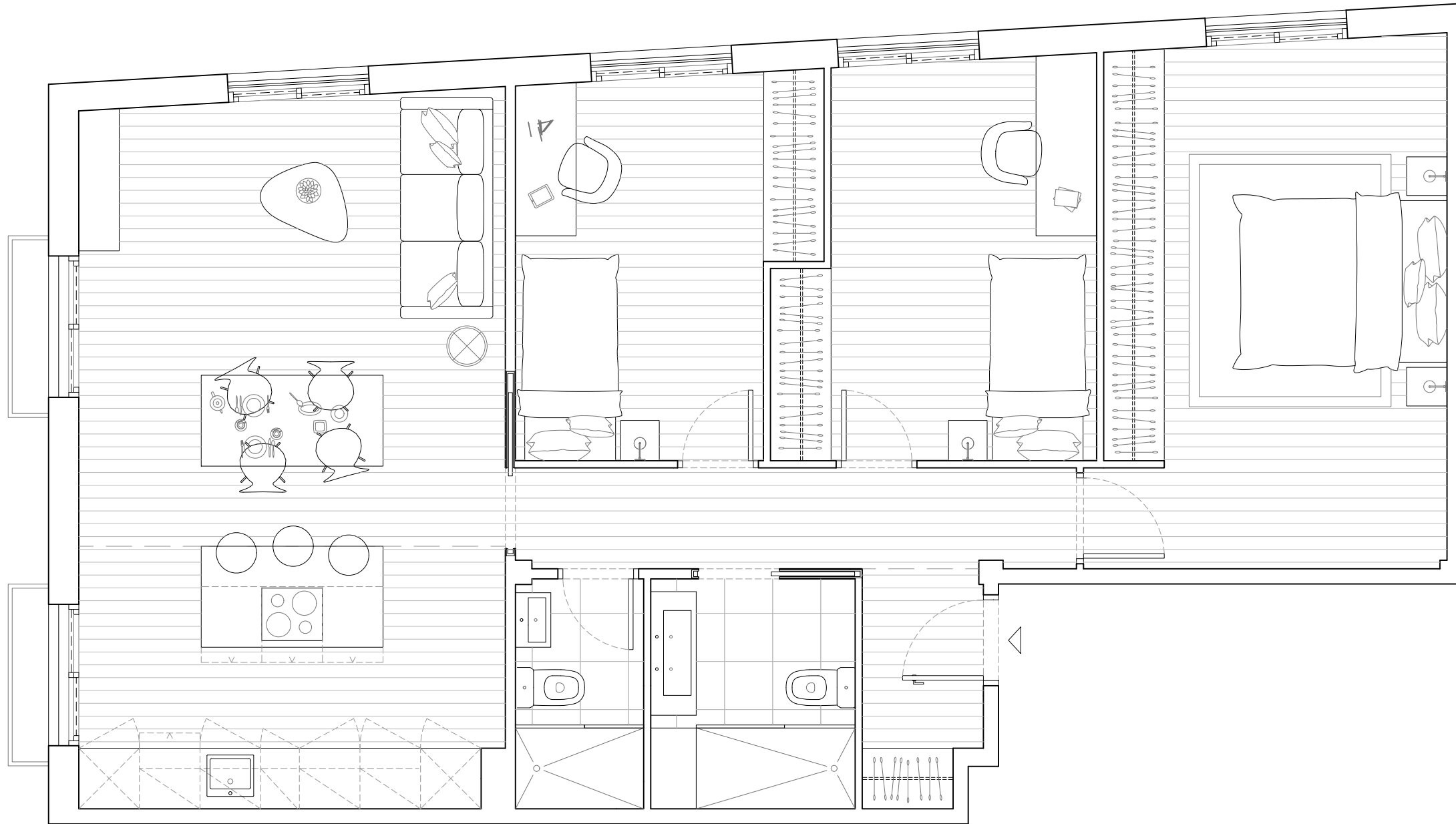

PLACETA DELS ARGENTERS

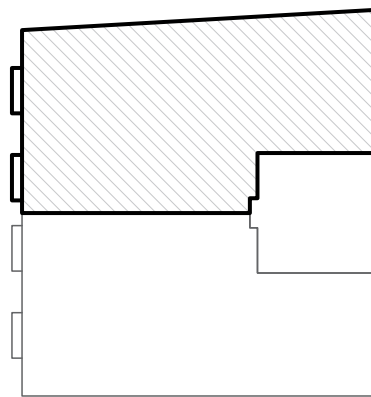

CARRER DEL VIDRE

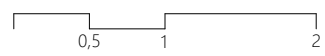
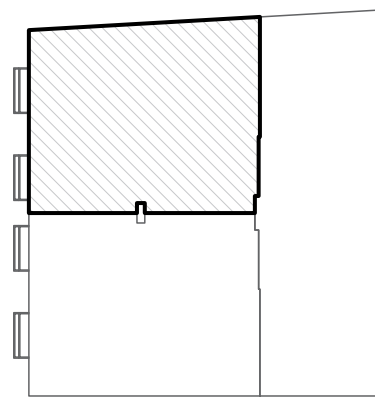

E: 1/50
A3

APCA
taller d'arquitectura
interiorisme i urbanisme

PLÀNOL
Pis tipus B
amb terrassa i piscina
Distribució



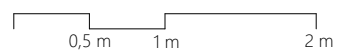
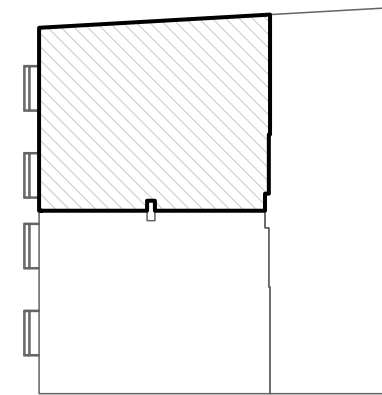
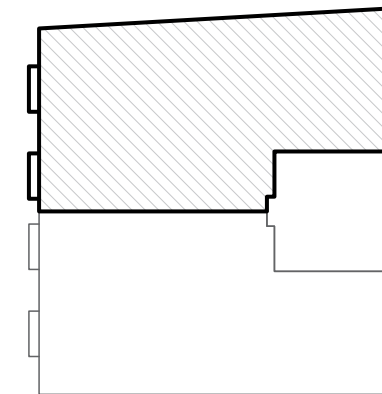
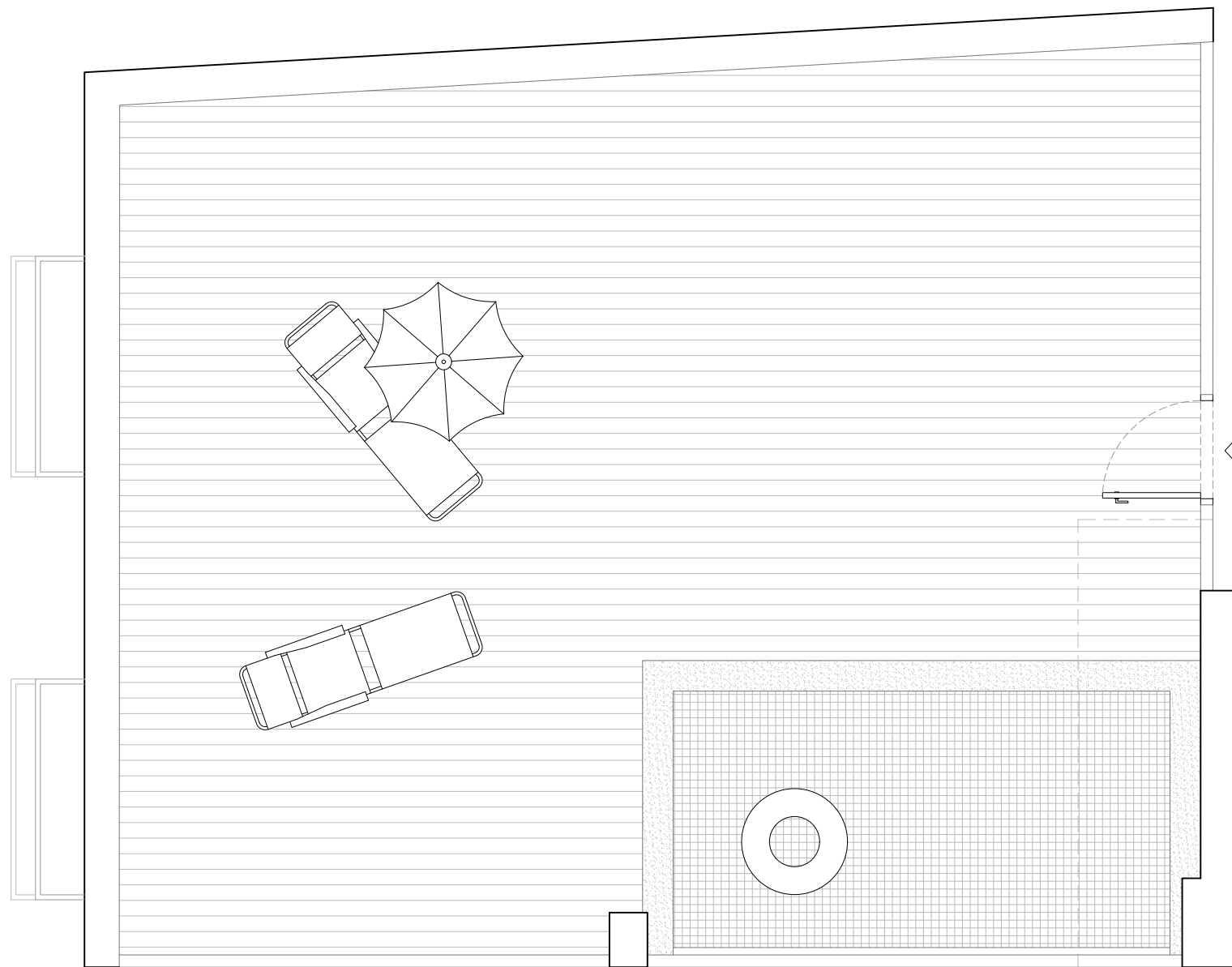

E: 1/50
A3

APCA
taller d'arquitectura
interiorisme i urbanisme

PLÀNOL
Pis tipus B
amb terrassa i piscina
Distribució

